

**SECTION B-B**

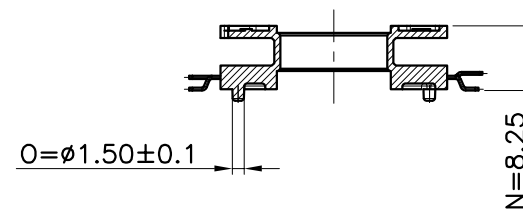

**SECTION A-A**

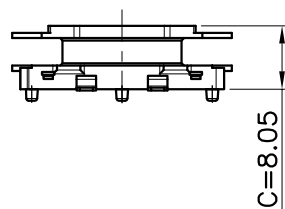
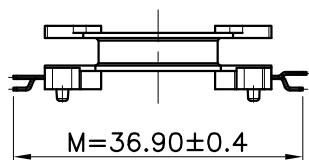
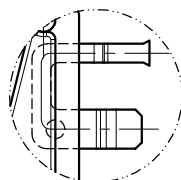
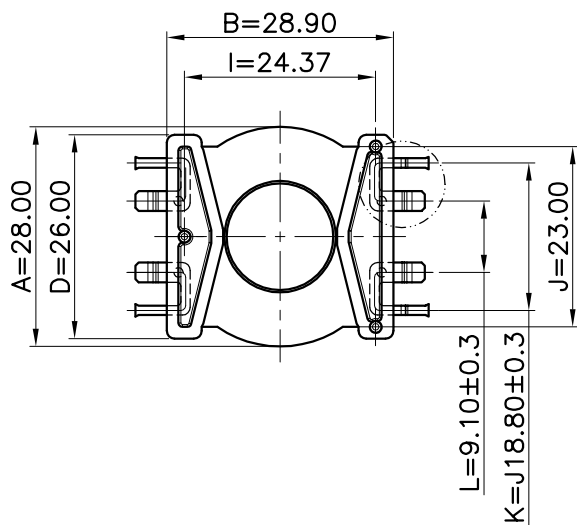

**DETAIL B  
SCALE 2:1**

MARK	REVISION NOTE	DATE	DRAWN	CHECKED	APPROVED	
△						
△						
△						
△						
DRAWN	CHECKED	APPROVED	MATERIAL : L.C.P	UL REC. : UL94V-0	THIRD ANGLE PROJ.	SCALE : 1/1
Sang Han, Kim	Hyoung Seok, Lee	Chul, Park		DATE : 2010.04.16	TOLERANCE : ±0.2 (Unless otherwise specified)	UNIT : m/m
주식회사 대흥보빈 DAE HEUNG BOBBIN CO., LTD			TITLE PQ 35*10 (4P) "V"		DWG NO DH-100629-6028-14	